

CD4430

ROUGH TERRAIN CRANE



Optional equipment shown and subject to change

LOW PROFILE. HIGH CAPACITY.

The Badger CD4430 Rough Terrain Crane features:

- Multiple boom configurations
- Four steering modes with auto alignment
- Rated capacity: 30 Ton (27.2 mT) at 10 ft. (3.0 m) working radius
- Maximum boom length: 75 ft. (22.86 m)
- Maximum tip height: 90 ft. (27.43 m)

CONTENTS

Dimensions

Notes	3
Crane Dimensions, Crane Weights	4
Range Diagram	5
Area of Operation	6













































Load Charts

Load Charts	7 & 8
-------------	-------

Technical Descriptions

Boom, Hoist, Rope and Hook	9
Superstructure, Cab, Controls, Operator Aids and Load Limiter / Load Indicator	10
Carrier, Engine, Drive-line and Hydraulic System	11
Vehicle Performance, Lighting	12

KEY

	Weight on front axle		Gross vehicle weight
	Swing on jib stowed		Weight on rear axle
	Lifting on wheels / Pick & carry		Standard (without hook block)
	Distance from hook to head sheave pin		Hook block
	Working radius		Counterweight
	Boom length		Telescoping mode
	General performance		Tip height
	Hydraulic actuated boom		Max. boom length with extension
	Boom elevation angle		Full power mechanically synchronized
	1 - Main hoist		3 - Recovery winch
	2 - Auxiliary winch		Boom with extension
	Rope - Standard/Optional		Hoist speed
	Rope length		Rope diameter
	Hook and ball		Maximum line pull
	Slewing locked / Slewing locked at specified position		Slewing / Allowable slewing range
	Slewing gears		Slewing brake
	Hydraulics		Engine
	Controls		Cab
	Mechanical transmission		Control Panel
	Steering		Operator aids/Load limiter Load indicator
	Tire		Outriggers / Lifting on outriggers
	Speed		Gradeability



Constant improvements and engineering progress make it necessary that Badger Equipment Company reserves the right to change designs, specifications and price changes without notice or obligation.

Drawings and/or photographs in this document are for illustrative purposes only and may include optional equipment and accessories and may not include all standard equipment. This document is non-contractual.

NOTES

- *Picking loads above operators compartment is not recommended*
- *Boom angles are undeflected boom angle*
- *All specifications are subject to change*
- *Loads above the blue line are based on structural competence*
- *Loads below the blue line are based on tipping*

1. All operators and support personnel shall read and fully understand manufacturer furnished operator's manual, latest applicable American National Standards Institute (ANSI) Safety Standards for Cranes, and any applicable federal, state, or local safety regulations before operating machine. Crane and load ratings comply with ANSI and Power Crane & Shovel Association (PCSA) Standards.

2. All "ON OUTRIGGER" lifts shall be made with outrigger arms fully extended to fully support and level machine (tires off supporting surface). Additional structural blocking or cribbing may be required for some applications.

3. All ratings below the heavy blue line are based on 85% of tipping load "ON OUTRIGGERS" and 75% of tipping "ON TIRES" with machine stable on firm level ground. Ratings above the heavy blue line are based on structural competence. Boom angles are undeflected boom angles.

4. DO NOT EXCEED crane load ratings. When load radius or boom angle are between listed values, use the smaller load rating. DO NOT ATTEMPT TO TIP MACHINE TO DETERMINE ALLOWABLE LOADS.

5. Weights of hook blocks, bucket, slings, and all other load handling devices are not accounted for in the load chart. The load handling devices must be considered as part of the load.

6. Reduce ratings appropriately for wind conditions, speed of operation, soft or uneven supporting surfaces, etc.

CAUTION - IN WIND OVER 30 MPH, CEASE OPERATION; POSITION BOOM AWAY FROM WIND AND LOWER BOOM BELOW 60°. IN WIND OVER 50 MPH, FULLY RETRACT AND LOWER BOOM TO LOWEST POSSIBLE POSITION.

7. Load ratings apply to this machine only as originally manufactured and equipped. Unauthorized modification or optional equipment may reduce load capacity. Please consult Badger Equipment BEFORE modification or use of optional equipment not covered in this chart.

8. **DO NOT** lift over operator cab.

9. **WARNING - These load ratings are for lift service only.**



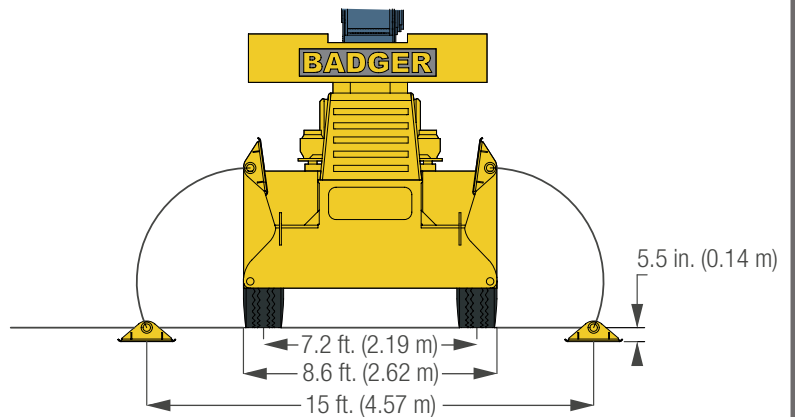
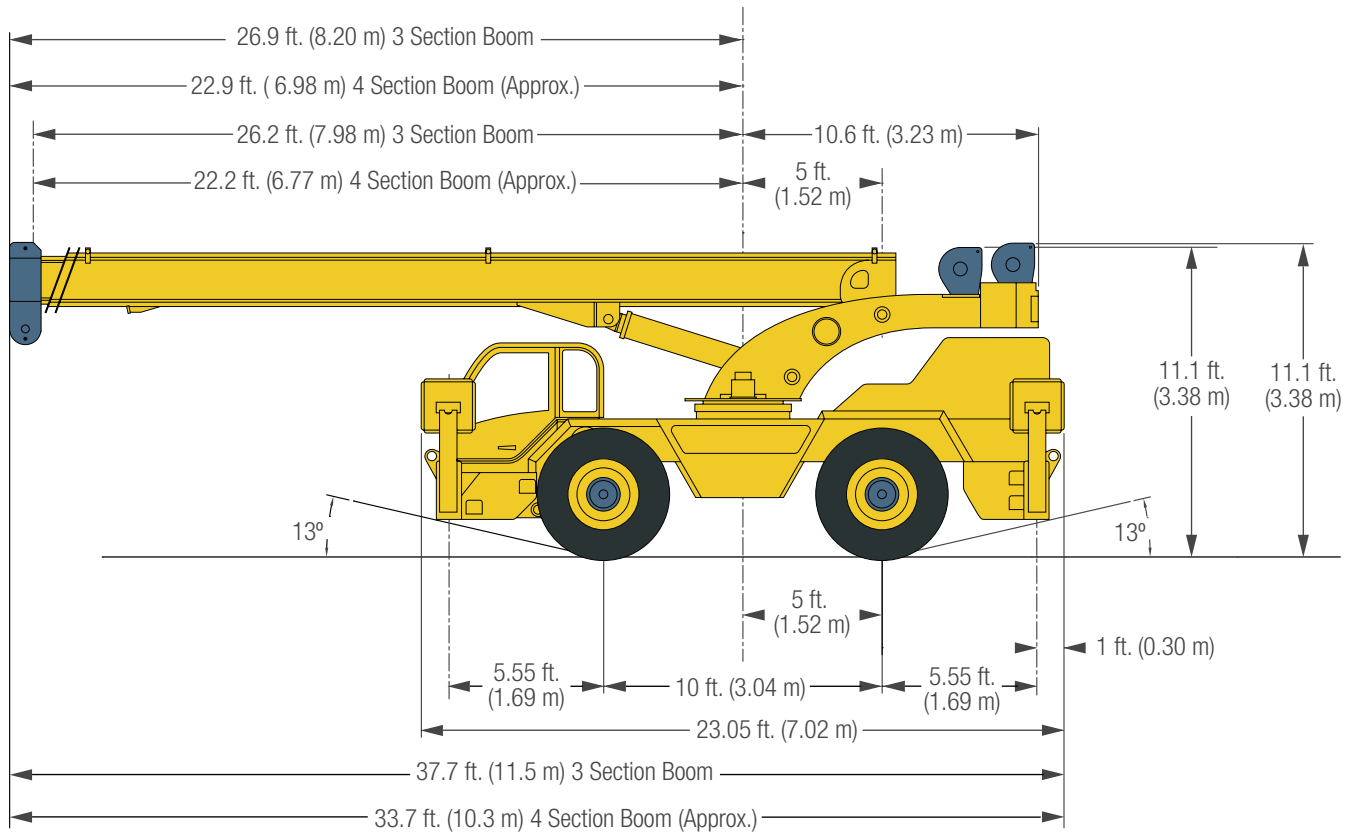

DIMENSIONS



NOTE:	CD4430	CD4420
Tire Size	16.00 x 25-32PR (L3-Lugs)	17 x 25
Track width	7.2 ft. (2.19 m)	6 ft. 9 in. (2.1 m)
Overall width	8.6 ft. (2.62 m)	8 ft. 4.9 in. (2.6 m)

CRANE WEIGHTS



 CD4430 Standard (Without hook block)	54,750 lb. (24,834 kg)	27,062 lb. (12,275 kg)	27,688 lb. (12,559 kg)
 CD4420 Standard (Without hook block)	52,000 lb. (23,586 kg)	25,702 lb. (11,658 kg)	26,298 lb. (11,928 kg)
 24 ft. (7.3 m) to 62 ft. (18.9 m) swing on jib stowed	+755 lb. (+342 kg)	+373 lb. (+169 kg)	+382 lb. (+173 kg)
 15T (13.6 mT) 2 sheave hook block	+415 lb. (+188 kg)	+578 lb. (+262 kg)	+592 lb. (+268 kg)
 7T (6.35 mT) hook & ball	+232 lb. (+105 kg)	+635 lb. (+288 kg)	+403 lb. (+183 kg)

RANGE DIAGRAM

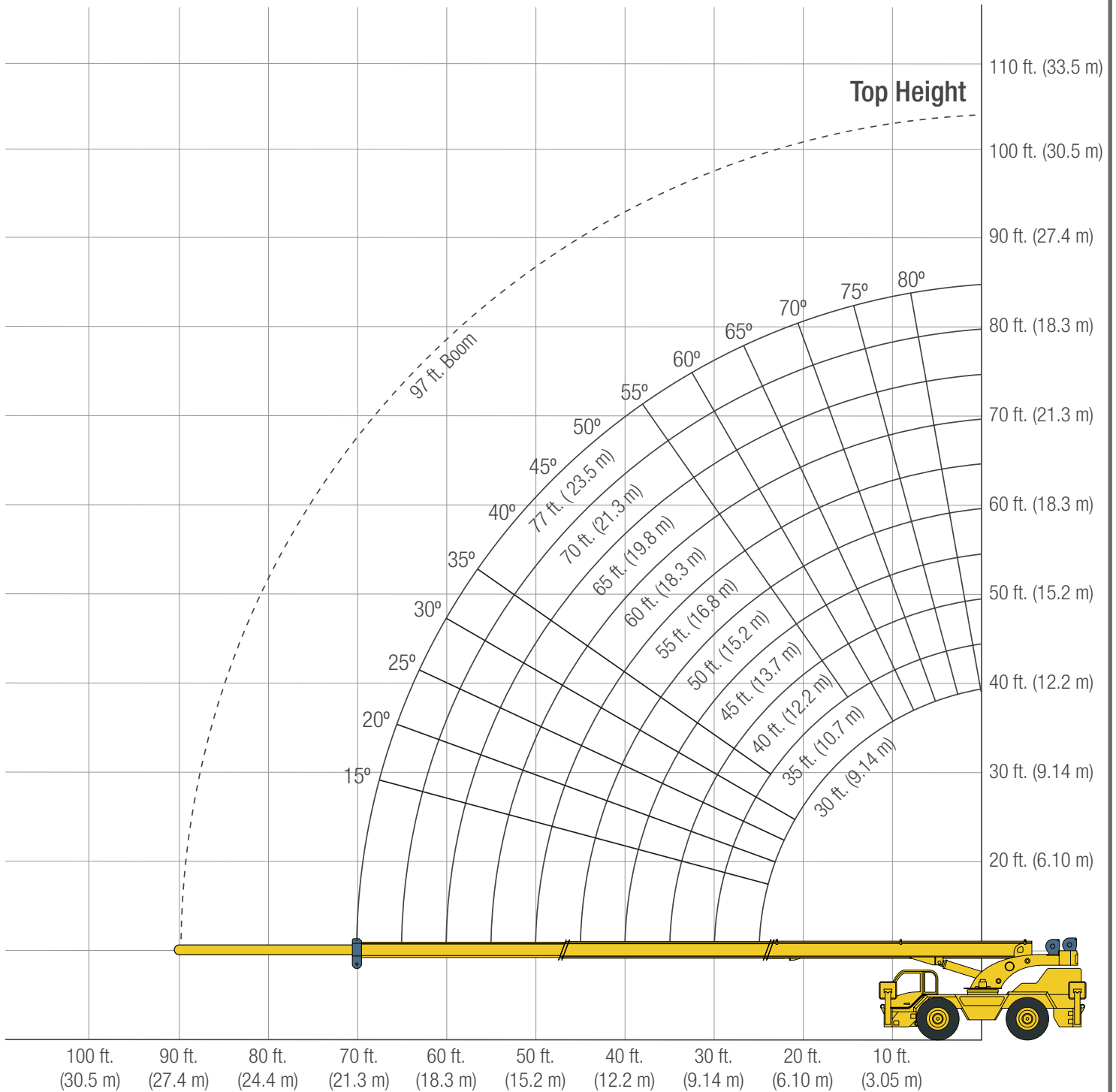

AREA OF OPERATION

ON OUTRIGGERS

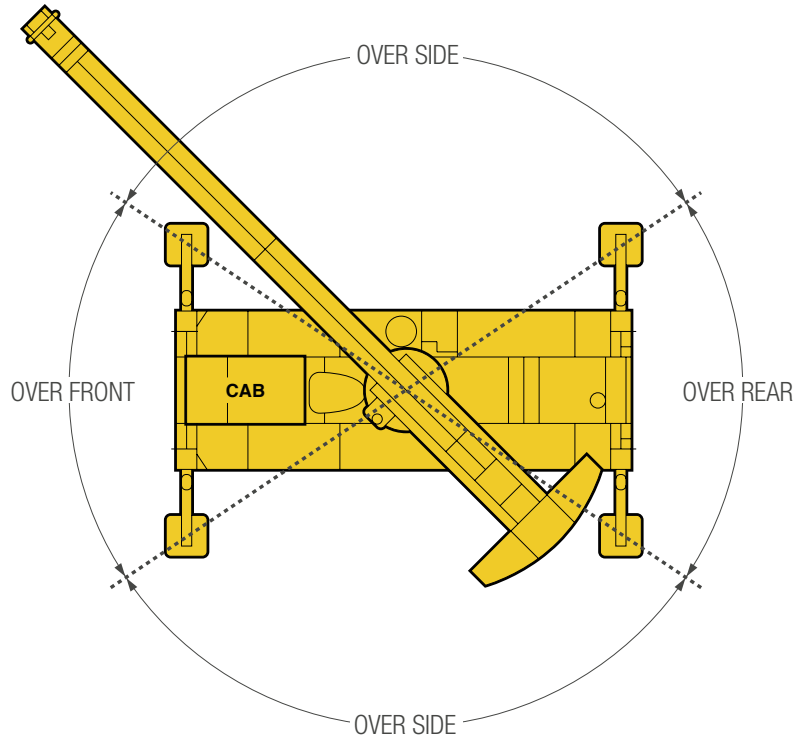

ON TIRES

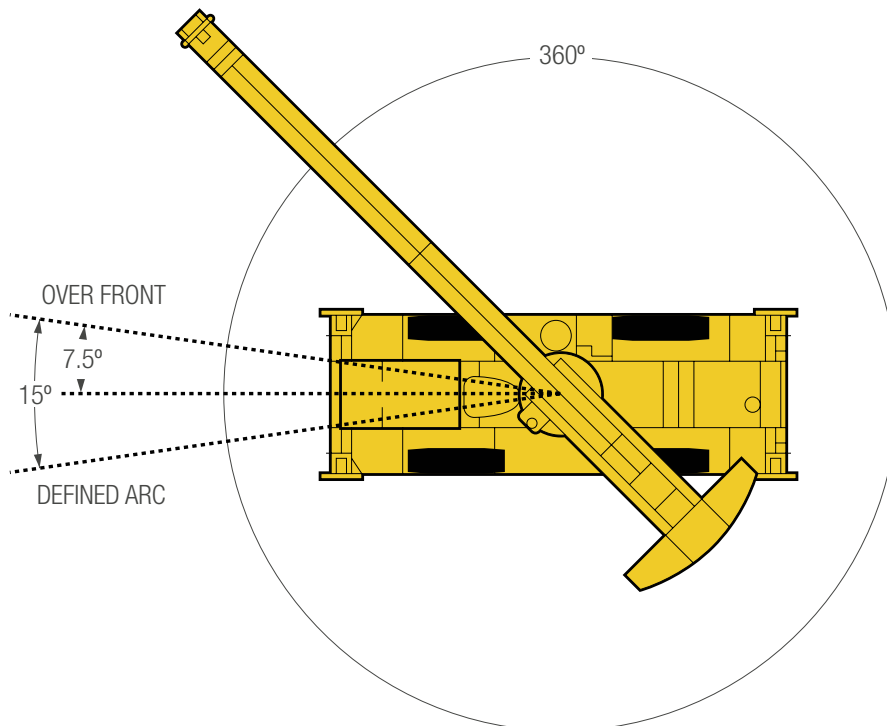

CD4420 LOAD CHART: Main Boom - On Outriggers

Lifting Capacities 3 Section Boom 31 ft. (9.45 m) - 75 ft. (22.86 m)  9,000 lb. (4,082 kg)  15 ft. (4.57 m) (100%)  360°

Boom Length (ft.)	31 ft. Boom			40 ft. Boom			50 ft. Boom			60 ft. Boom			70 ft. Boom			75 ft. Boom		
	Boom Angle (Deg)	Over Front (lbs.)	360° (lbs.)	Boom Angle (Deg)	Over Front (lbs.)	360° (lbs.)	Boom Angle (Deg)	Over Front (lbs.)	360° (lbs.)	Boom Angle (Deg)	Over Front (lbs.)	360° (lbs.)	Boom Angle (Deg)	Over Front (lbs.)	360° (lbs.)	Boom Angle (Deg)	Over Front (lbs.)	360° (lbs.)
10 ft.	61°	40,000	40,000	68°	40,000	40,000												
12 ft.	57°	33,300	33,300	65°	33,300	33,300	70°	33,000	33,000									
15 ft.	50°	26,600	26,600	60°	26,600	26,600	66°	26,600	26,600	71°	26,600	26,600						
20 ft.	36°	20,000	20,000	51°	20,000	20,000	60°	20,000	20,000	65°	20,000	20,000	69°	20,000	20,000			
25 ft.	15°	16,000	16,000	41°	16,000	16,000	53°	16,000	16,000	60°	16,000	16,000	65°	16,000	16,000	66°	16,000	16,000
30 ft.				29°	13,300	13,300	46°	13,300	13,300	54°	13,300	13,300	60°	13,300	13,300	62°	13,300	13,300
35 ft.				0°	11,400	10,600	37°	11,400	10,600	48°	11,400	10,600	55°	11,400	10,600	58°	11,400	10,600
40 ft.							26°	10,000	8,500	41°	10,000	8,500	50°	10,000	8,500	53°	10,000	8,500
45 ft.							0°	8,500	6,800	34°	8,850	6,800	44°	8,850	6,800	48°	8,850	6,800
50 ft.										24°	8,000	5,500	38°	8,000	5,500	43°	8,000	5,500
55 ft.										0°	6,800	4,650	31°	6,800	4,750	37°	6,800	4,750
60 ft.													22°	5,950	4,000	30°	5,950	4,000
65 ft.													0°	5,650	3,400	21°	5,650	3,400
70 ft.																0°	5,400	2,950

On TIRES*







Max Boom Length (ft.)	Pick and Carry				
	Stationary	Creep	2.5 MPH	Straight Over Front (lbs.)	
10 ft.	31	18,000	26,000	18,400	14,600
12 ft.	31	13,700	22,900	16,200	12,800
15 ft.	40	10,100	19,500	13,800	10,900
20 ft.	40	7,000	15,000	11,000	8,700
25 ft.	45	5,000	11,000	9,000	7,300
30 ft.	45	3,000	7,000	7,000	6,000
35 ft.	45	2,000	6,000	6,000	5,000
40 ft.	53	1,500	5,000	5,000	4,000
45 ft.	60		3,500	3,500	3,500
50 ft.	65		3,000	3,000	3,000
55 ft.	70		2,000	2,000	2,000
60 ft.	70		1,400	1,400	1,400
65 ft.	75		1,000		

*Tires (17.5 x 25-20 PR)

Recommended Tire Pressure

Tire Size	Stationary	Creep	2.5 MPH	Travel
16.00 x 25-32 PR	125 PSI	125 PSI	95 PSI	95 PSI
17.5 x 25-20 PR	90 PSI	90 PSI	90 PSI	70 PSI

Allowable Line Pull (Lbs)

1 Part Line	2 Part Line	3 Part Line
		
10,000	20,000	30,000
4 Part Line	5 Part Line	6 Part Line
		
40,000	50,000	60,000

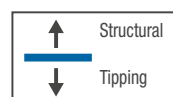

CD4430 LOAD CHART: Main Boom - On Outriggers

Lifting Capacities 3 Section Boom 30.5 ft. (9.30 m) - 76.8 ft. (23.41 m)  9,000 lb. (4,082 kg)  15 ft. (4.57 m) (100%)  360°

Boom Length (ft.)	31 ft. Boom			40 ft. Boom			50 ft. Boom			60 ft. Boom			70 ft. Boom			76.8 ft. Boom		
	Boom Angle (Deg)	Over Front (lbs.)	360° (lbs.)	Boom Angle (Deg)	Over Front (lbs.)	360° (lbs.)	Boom Angle (Deg)	Over Front (lbs.)	360° (lbs.)	Boom Angle (Deg)	Over Front (lbs.)	360° (lbs.)	Boom Angle (Deg)	Over Front (lbs.)	360° (lbs.)	Boom Angle (Deg)	Over Front (lbs.)	360° (lbs.)
10 ft.	61°	60,000	60,000	68°	55,000	55,000												
12 ft.	56°	50,000	50,000	65°	50,000	50,000	70°	45,000	45,000									
15 ft.	49°	40,000	40,000	60°	40,000	40,000	66°	37,500	37,500	71°	35,000	35,000						
20 ft.	35°	30,000	25,500	51°	30,000	25,500	60°	29,000	25,500	65°	28,000	25,500	69°	28,000	25,500			
25 ft.	10°	24,000	17,000	41°	24,000	17,000	53°	24,000	17,000	60°	24,000	17,000	65°	22,000	17,000	67°	20,000	17,000
30 ft.				29°	20,000	14,000	46°	18,000	14,000	54°	17,000	14,000	60°	16,500	14,000	63°	16,500	14,000
35 ft.				0°	17,100	10,600	37°	17,000	10,600	48°	16,500	10,600	55°	15,700	10,600	59°	15,000	10,600
40 ft.							26°	11,900	8,500	41°	11,900	8,500	50°	11,900	8,500	54°	11,900	8,500
45 ft.							0°	9,300	6,800	34°	9,300	6,800	44°	9,300	6,800	49°	9,300	6,800
50 ft.										24°	8,000	5,500	38°	8,000	5,500	44°	8,000	5,500
55 ft.										0°	6,800	4,650	31°	6,800	4,750	39°	6,800	4,750
60 ft.													22°	5,950	4,000	32°	5,950	4,000
65 ft.													0°	5,650	3,400	24°	5,650	3,400
70 ft.																12°	5,400	2,950

On TIRES*

Pick and Carry

Max Boom Length (ft.)	Stationary		Creep		2.5 MPH
	360° (lbs.)	Over Front Defined Arc (lbs.)	Over Front Defined Arc (lbs.)	Straight Over Front (lbs.)	Straight Over Front (lbs.)
10 ft.	31	18,000	33,000	25,000	21,000
12 ft.	31	13,700	29,000	22,000	18,000
15 ft.	40	10,100	23,000	17,500	15,000
20 ft.	40	7,000	15,000	13,000	11,000
25 ft.	45	5,000	11,000	9,000	8,000
30 ft.	45	3,000	7,000	7,000	6,000
35 ft.	45	2,000	6,000	6,000	5,000
40 ft.	53	1,500	5,000	5,000	4,000
45 ft.	60		3,500	3,500	3,500
50 ft.	65		3,000	3,000	3,000
55 ft.	70		2,000	2,000	2,000
60 ft.	70		1,400	1,400	1,400
65 ft.	75		1,000		

*Tires (16.00 x 25-32PR (L3-Lugs))

Winch Data

5/8 Wire Rope, 39.6 gpm, 3200 psi Pressure Drop

Layer	Capacity (ft.)	Low Speed		High Speed	
		Lift (lbs.)	Speed (fpm)	Lift (lbs.)	Speed (fpm)
1	80	12708	159	7786	260
2	168	11437	177	7008	289
3	265	10398	194	6371	317
4	372	9531	212	5840	346
5	487	8798	230	5391	375
6	611	8170	248	5006	404

Recommended Tire Pressure

Tire Size	Stationary	Creep	2.5 MPH	Travel
16.00 x 25-32 PR	125 PSI	125 PSI	125 PSI	95 PSI

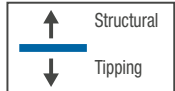

20' Jib On Outriggers		
Boom Angle (Deg)	Boom Radius (ref ft.)	360° (lbs.)
70.0°	25	14,100
66.7°	30	12,900
63.4°	35	11,850
60.0°	40	10,600
56.6°	45	8,750
53.0°	50	7,350
49.4°	55	6,250
45.5°	60	5,350
41.4°	65	4,600
37.0°	70	4,000
32.2°	75	3,450
26.5°	80	3,000
19.7°	85	2,600
9.7°	90	2,250

TECHNICAL DESCRIPTION

Boom

Standard Configuration:



(3) section 77 ft. boom of four sided box type construction with (1) double acting telescopic cylinder. The cylinder is equipped with integral holding valves. Accessible wear pads for both vertical and horizontal forces support boom sections. Made of formed and welded high-tensile steel plate for maximum strength and weight ratio.



Full power mechanically synchronized



Boom (min. / max.): 31 ft. / 77 ft. (9.45 m / 23.5 m)



Boom elevation angle range (min. / max.): 0° / 71°

Optional Configuration:



- + 20' swing-away side-stowed jib with super small jib head
- + Manual boom angle

Hoist, Rope and Hook

Standard Configuration:



Grooved storage capacity: 611 ft. (186.2 m)



Max high speed: 404 fpm (123.1 m/min)
 Max low speed: 248 fpm (75.6 m/min)
 See chart on page 8 for layer capacity and lift speed



6 x 19 IWRC XIPS, Right regular lay, preformed



Rope diameter: .625 in. (14.3 mm)



Rope length: 433 ft. (132 m)



Max. line pull: 1st layer low-range 12,510 lbs.
 Max. line pull permissible: 9,000 lbs.



7 Ton hook and ball: 180 lb. (82 kg)

Optional Configuration:

- + Auxiliary Winch - grooved storage capacity: 611 ft. (186.2 m)
- + 35 Ton (35.5 mT) Easy Reeve® hook block 1-7 parts line + Hook block assembly
- + 30 Ton (30.5 mT) hook block 1-7 parts line

Superstructure

Standard Configuration:



Continuous 360°

Maximum rotation speed without load:

3 rpm



Hydraulic motor

Planetary reducer

Spring applied hydraulic released brakes



Swingbrake is heavy duty multiple disk actuated automatically from the operators cab.

Two (2) position swing lock for pick and carry as well as travel modes.

Cab, Controls, Operator Aids and Load Limiter/Indicator

Standard Configuration:



Fully enclosed one (1) person high visibility pressurized cab, mounted on the front center of the carrier. All steel construction; has two (2) hinged entry doors with tinted safety glass windows and shatter resistant windshield and roof glass.

Cab Features:

- Air conditioning, automotive dash style
- Two each lockable exit doors (right and left side with pneumatic spring design)
- Sliding windows in doors and rear
- Mirrors
- Fire extinguisher
- Adjustable sun visor
- Windshield wiper
- Heater and defroster - 12000 btu hot water
- Eleven way adjustable, cloth cushioned seat with seat belt



Fuel level

Tachometer

Speedometer

6.5" LCD CANbus display

Engine oil pressure

Hydraulic oil pressure, temp and level

Engine water temperature and level

Torque converter oil temperature

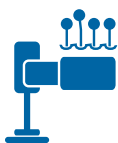

Armrest mounted dual axis electro-proportional joysticks

Steering wheel column with gear selector on the right and directional light selector on the left

Dashboard mounted switches for outrigger operation

Optional Configuration:



- + Safety rail
- + Cab vandal and protection screen (all windows)
- + Front windshield protection screen (required with recovery winch)
- + Slow moving vehicle sign
- + Rear view camera with color monitor in cab dash (1 camera)
- + Extra mirrors to view outriggers
- + Telematics
- + AM/FM radio

LMI System

Standard Configuration:



Graphic interface with load indicator and control joystick cutout function

Carrier, Engine, Drive-line and Hydraulic System

Standard Configuration:



Hydraulic Independent Extension

Outrigger pad size:

16 in. x 16 in. (406 mm x 406 mm)

Area of outrigger pads:

256 in.² (1,652 cm²)



Cummins® QSB 6.7 diesel engine, 6-cylinders

Rated power:

160 hp (119.31 kw) @ 2,500 rpm

Intake:

Turbocharger with intercooler

Fuel type:

Diesel

Fuel tank capacity:

75 gal. (284 L)

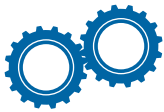

6 x 6 powershift transmission with integral torque converter

- 3 forward speeds, high range

- 3 forward speeds, low range

- Rear axle disconnect

Auto centering axles



Hydraulic four wheel power steering with tilt steering column

Hydraulic type steering with 4 steering modes:

- 2 wheel front

- 4 wheel coordinated

- 2 wheel rear

- 4 wheel crab

Front: Rigid, front planetary type steer axle

Rear: Oscillating rear planetary steer axle.

Suspension: Oscillation with hydraulic lockout device

Synchronized auto centering is standard



Hydraulic Pump:

3 variable piston pumps for all crane functions

Hydraulic oil reservoir capacity (with oil level and temperature indicator):

110 gal. (416.4 L)

Hydraulic oil return filter:

10 micron with bypass protection

Optional Configuration:



⊕ Hydraulic Tool Ports

Optional Configuration:



⊕ Recovery Winch (Windshield Protection Screen required)

Vehicle Performance

Standard Configuration:

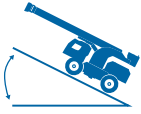

Maximum Gradeability:

Up to 61.5%



Maximum Speed (6th gear)
Cummins® Engine:

25 mph (40 kph)

Lighting

Standard Configuration:



The following lights are furnished and installed:

- Two (2) brake/turn taillights.
- Two (2) sealed beam headlights with turn signals.

Optional Configuration:



- + Optional four (4) work lights. Optional perimeter lighting.
- + Optional strobe lights.
- + LED work lights

Notes:



217 Patneau Drive | Winona, MN 55987
(800) 533-8013 | (507) 454-1563
www.BadgerEquipment.com



A Manitex International Company