

# Specifications

Hydraulic Rough Terrain Crane

GENERAL INFORMATION ONLY

## HSP-8015

15 Ton (13.61 metric ton)

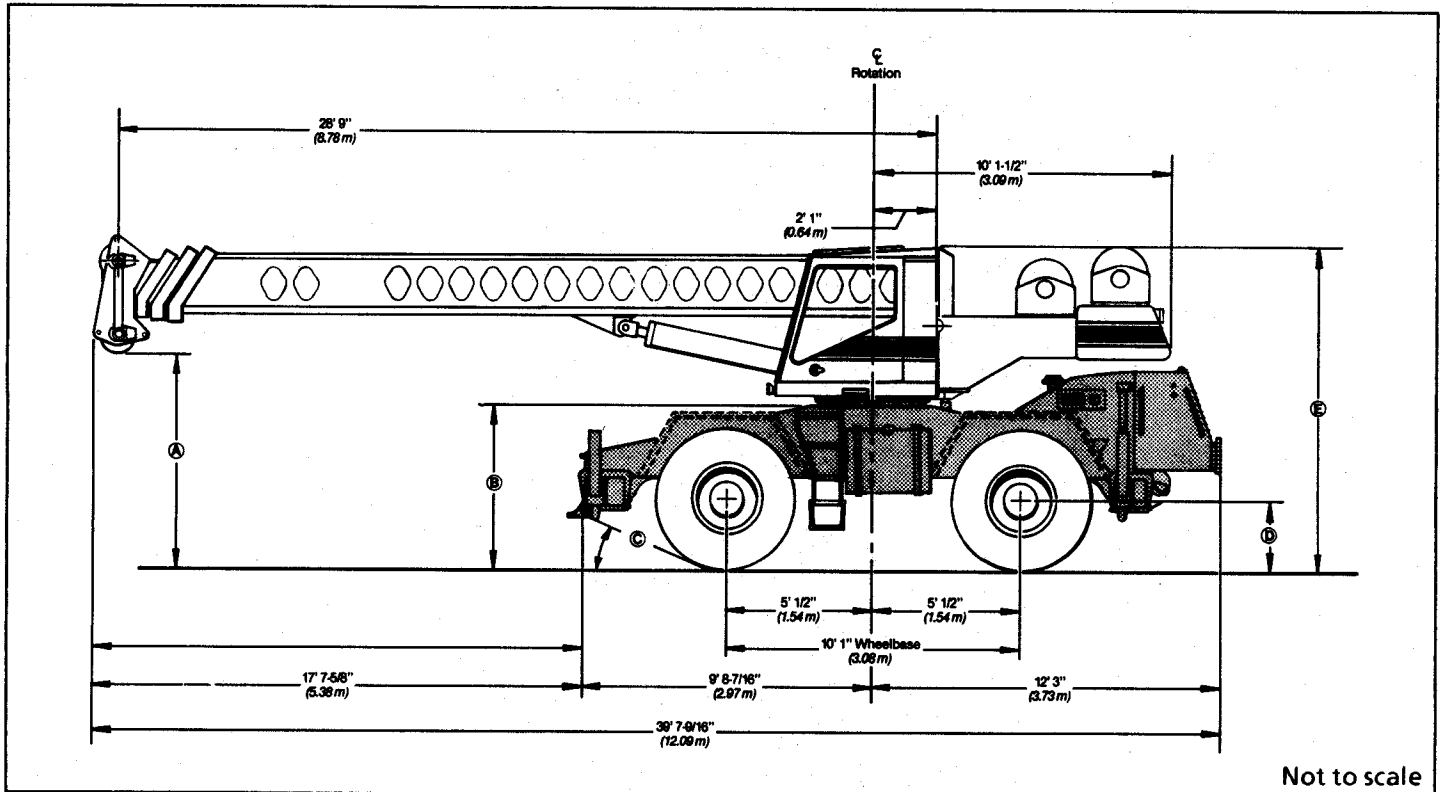

Not to scale

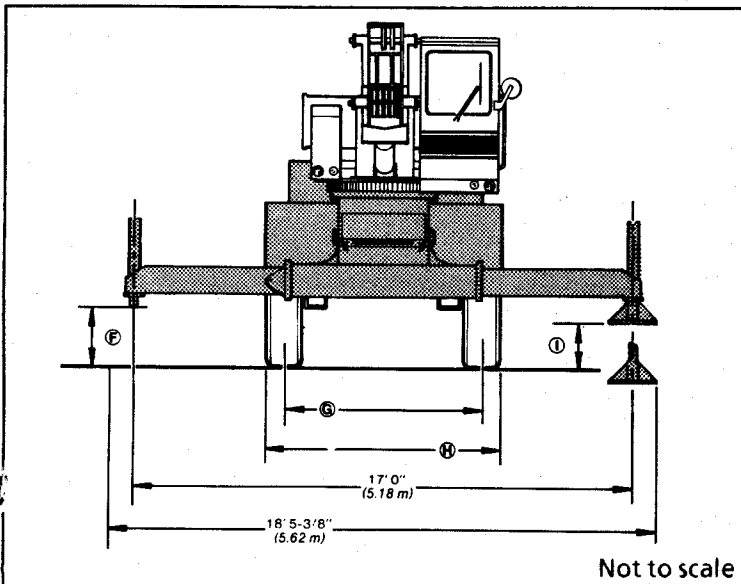

Not to scale

| General dimensions             | feet    | meters |
|--------------------------------|---------|--------|
| Turning Radius (4-wheel steer) | 14' 11" | 4.55   |
| Tailswing of counterweight:    | 10' 6"  | 3.20   |

### Dimensions affected by tires

| Tires | 16.0 X 24 (16-PR) |        | 20.5 X 25 (20-PR) |        |
|-------|-------------------|--------|-------------------|--------|
|       | feet              | meters | feet              | meters |
| A     | -                 | -      | 8' 3/4"           | 2.46   |
| B     | 5' 7-5/16"        | 1.71   | 5' 8-1/4"         | 1.73   |
| C     | 19.4°             | -      | 20°               | -      |
| D     | 2' 1-13/16"       | 0.66   | 2' 4-9/16"        | 0.73   |
| E     | 11' 7/16"         | 3.36   | 11' 1-3/8"        | 3.39   |
| F     | 20-1/8"           | 0.51   | 21"               | 0.53   |
| G     | 6' 6-7/16"        | 1.99   | 6' 11-7/16"       | 2.12   |
| H     | 8' 0"             | 2.44   | 8' 8-13/16"       | 2.66   |
| I     | 12-1/8"           | 0.31   | 13"               | 0.33   |

# Upperstructure

## Boom

Link-Belt patented design. Boom side plates have diamond shaped impressions for superior strength to weight ratio and 100,000 p.s.i. (689.5 MPa) steel angle chords for lateral stiffness. Boom telescope sections are supported by wear shoes both vertically and horizontally to prevent metal to metal contact. Anti-two block, electronic boom length / angle indicator and function kickout.

**Load Moment Indicator — Optional;** Audio-visual warning system with anti-two block and function kickouts. Constant display of boom length and angle, tip height, radius of load, machine configuration, allowed load, actual load and % of allowed load. Presettable alarms for maximum and minimum boom angles, maximum tip height and maximum boom length.

**Standard boom — 28' 9" — 70' 3"** (8.76 m — 21.41 m) three-section boom with two power sections.

**Optional boom — 28' 9" — 49' 6"** (8.76 m — 15.09 m) 2-section boom with one power section.

**Optional boom — 28' 9" — 91' 0"** (8.76 m — 27.74 m) 4-section boom includes 2-section, two power sections, and manual fourth section. Fourth section is power pinned by manually activating a cylinder locking system.

**Boom head — Standard;** Four 10-5/8" (0.27 m) root diameter head sheaves handle up to 8 parts of wire rope. Two easily removable wire rope guards and rope dead end lugs provided on each side of boom head. Optional 12-1/8" (0.31 m) root diameter head sheaves; meets 23:1 ratio European safety code with 9/16" (14 mm) wire rope.

**Auxiliary lifting sheave — Optional;** Single 10-5/8" (0.27 m) root diameter sheave with removable wire rope guard, mounted to boom. For use with one or two parts of line off the optional auxiliary winch. Does not affect erection of fly, or use of main head sheaves for multiple reeving.

**Boom elevation —** One Link-Belt designed hydraulic cylinder with holding valve. Self aligning steel bushings. Hand and optional foot controls for controlling boom elevation from 3° to 80°.

## Fly

**Optional — 24' 0" (7.32 m)** stowable one-piece lattice type.

## Jib

**Optional — 14' 6" (4.42 m)** stowable A-frame. Attaches to boom head only. Can be offset 10°, 20° and 30°.

## Cab and Controls

Environmental cab; isolated from sound and vibration by rubber mounts. All tinted and tempered safety glass windows. Sliding rear and right side window and swing up roof window for maximum visibility and ventilation. Slide-by-door opens to 3' 0" (0.91 m) width. 6-way adjustable operator's seat. 4-way adjustable lift/telescoping steering wheel. Ignition and steering wheel key lock. Control levers for swing, boom telescope, winch and boom hoist. Outrigger controls, sight level bubble. Optional foot control for boom hoist and swing brake.

**Cab instrumentation —** Dash mounted gauges for hydraulic oil temperature, converter temperature, fuel, water temperature, voltmeter and oil pressure.

## Swing

Bi-directional hydraulic swing motor mounted to a planetary reducer for 360° continuous smooth swing at 3.0 r.p.m.

**Swing parking brake —** Manually applied/released, disc brake mounted on the speed reducer.

**Swing brake — Optional;** foot operated, spring released disc brake mounted on the speed reducer.

**Swing lock — Standard;** two position travel lock operated from the operator's cab. Optional 360 house lock.

**Counterweight —** Bolted to upperstructure frame.

## Hydraulic System

**Main pump —** Double gear type pump. Combined pump capacity 92 gpm (348.2 lpm). Powered by carrier engine through a straight mechanical drive or through an optional mechanical clutch pump disconnect. Pump operates at 2,800 p.s.i. (193.05 Bars) maximum system pressure.

**Swing / steering pump —** Single gear-type pump, 15 gpm (56.8 lpm) maximum. Powered by carrier engine through a straight mechanical drive. Pump operates at 2,500 p.s.i. (172.37 Bars).

**Reservoir —** 100 gallon (378.50 L) capacity. Double diffusers for deaeration.

**Filtration —** Two 2-micron filters located inside of hydraulic reservoir. Accessible for easy replacement.

**Control valves —** Five separate control valves allow simultaneous operation of all crane functions.

## Load Hoist System

**Standard:** 1M main winch with single speed motor and automatic brake; power up/down mode of operation. Bi-directional gear-type hydraulic motor, driven through a double planetary reduction unit for positive operator control under all load conditions.

**Optional —** Model 2M main winch with two-speed motor and automatic brake, power up/power down mode of operation. Bi-directional, gear-type hydraulic motor.

**Optional —** Model 1M auxiliary winch with one-speed motor and automatic brake, power up/power down mode of operation.

**Line pulls and speeds —** Maximum line pull 9,600 lbs. (4 355 kg) and maximum line speed of 416 f.p.m. (126.80 m/min) on standard 12" (0.30 m) root diameter smooth drum.

## Additional Equipment - Standard

Sound suppressed cab, fire extinguisher, seat belt, warning horn, mirrors, travel lights, windshield wiper and backup alarm.

## Additional Upperstructure Equipment - Optional

360° house lock, boom hoist foot control, propane heater, diesel heater, foot actuated swing brake, two-speed main winch, drum rotation indicators, 25-ton (22.68 metric ton) hook block, 30-ton (27.22 metric ton) hook block, 8-1/2 ton (7.71 metric ton) hook ball and swivel, rear steer indicator, boom mounted working light, engine monitoring system, tachometer, air conditioner, top hatch window wiper, amber rotating beacon, windshield washer, and 360° cab mounted spotlight.

# Carrier

## Type

Link-Belt 8' 0" (2.44 m) wide, 121" (3.07 m) wheelbase.

4 x 4 x 4 — (4-wheel steer, 4-wheel drive)

**Standard** — for rough terrain with limited turning area.

4 x 4 x 4 — (4-wheel steer, 4-wheel drive)

**Optional** — Rear axle with no-spin differential; for rough terrain with limited turning area.

**Frame** — 100,000 p.s.i. (689.5 MPa) steel, double walled construction with integral 100,000 p.s.i. (689.5 MPa) steel outrigger boxes.

## Axles

**Front - Standard** — heavy duty planetary drive/steer type.

**Rear - Standard** — heavy duty planetary drive/steer type.

**Rear - Optional** — heavy duty no-spin differential, planetary drive/steer type.

## Suspension

**Front axle** — Rigid mounted to frame.

**Rear axle** — Pin-mounted on welded steel box cradle. Automatic hydraulic rear axle oscillation lock-out engages when upperstructure rotates past 2-1/2° of centerline.

## Tires

**Front and rear**

**Standard** — 20.5 x 25 (20-PR)

**Optional** — 16.0 x 24 (16-PR)

## Brakes

**Service** — Air over hydraulic, drum-type brakes at each wheel end. Drum diameter 17-1/2" (0.44 m). Shoe width 4" (.10 m).

**Parking** — Spring applied, air released; cab controlled, mounted on front axle.

## Steering

Hydraulic two wheel, four wheel and "crab" steering; controlled from tilt / telescoping steering wheel.

## Transmission

4-speed fully automatic transmission. 8 speeds forward and 2 reverse with 2-speed heavy duty transfer case. Electric over air controls. Completely automatic shifting in both low and high range for operator convenience.

## Outriggers

Four hydraulic, telescoping beam and jack outriggers. Vertical jack cylinders equipped with integral holding valve. Beams extend to 17' 0" (5.18 m) centerline-to-centerline and retract to within 8' 0" (2.44 m) overall width. Equipped with stowable, lightweight 17-3/8" (0.44 m) square steel floats. Controls and sight level bubble located in upperstructure cab.

## Additional Equipment - Standard

Cab steps, 2 front and rear carrier steps, skid resistant finish on carrier deck, storage compartment, automatic rear axle disconnect, and fenders.

## Additional Equipment - Optional

No-spin differential on rear axle, front and rear towing shackles, lifting lug package, engine block heater, ether injection package, spare tires and rims, pintle hook, manual pump disconnect, auxiliary steering system, air dryer, and jack cylinder hose covers.

## Travel Speeds and Gradeability

| Engine  | Tires     | Maximum Speed |      | Gradeability at stall | Maximum tractive effort at stall |        | Gradeability at 1.0 mph (1.61 km/h) | Maximum tractive effort at 1.0 mph (1.61 km/h) |        |
|---------|-----------|---------------|------|-----------------------|----------------------------------|--------|-------------------------------------|--|--------|
|         |           | mph           | km/h |                       | pounds                           | kg     |                                     | pounds   | kg     |
| GM 8.2N | 16.0 x 24 | 18.1          | 29.1 | 186%                  | 39,886                           | 18 092 | 66%                                 | 25,148   | 11 407 |
|         | 20.5 x 25 | 19.4          | 31.2 | 130%                  | 37,090                           | 16 824 | 60%                                 | 24,210   | 10 982 |

| Engine             | GM 8.2N                              |
|--------------------|--------------------------------------|
| Cylinders - cycle  | 8-4                                  |
| Bore               | 4.25" (108.0 mm)                     |
| Stroke             | 4.41" (112.0 mm)                     |
| Displacement       | 500 cu. in. (8 200 cm <sup>3</sup> ) |
| Maximum brake hp   | 130 @ 2800 rpm                       |
| Peak torque        | 330 ft. lbs. (447 J)                 |
| Electric system    | 12 volt negative ground              |
| Fuel capacity      | 75 gallons (283.9 L)                 |
| Alternator         | 80 amps                              |
| Crankcase capacity | 12 quarts (11.4 L)                   |
| Air compressor     | 12 c.l.m. (0.34 m <sup>3</sup> /min) |

**Axle Loads 3-Section Boom**

| Base machine with standard<br>28' 9" - 70' 3" (8.67 m - 21.41 m)<br>three-section boom, 400' (121.92 m)<br>9/16" (14 mm) wire rope, 4 x 4 x 4<br>carrier with GM 8.2N engine, 20.5 x<br>25.0 tires, counterweight. | G.V.W. ① |        | Upper facing front |        |           |        | Upper facing rear |        |           |        |
|--|----------|--------|--------------------|--------|-----------|--------|-------------------|--------|-----------|--------|
|  |          |        | Front axle         |        | Rear axle |        | Front axle        |        | Rear axle |        |
|  | lbs.     | kg     | lbs.               | kg     | lbs.      | kg     | lbs.              | kg     | lbs.      | kg     |
|  | 45,987   | 20 860 | 22,862             | 10 370 | 23,124    | 10 489 | 17,436            | 7 909  | 28,550    | 12 950 |
| 28'9"-91'0" (8.76 m - 27.74 m) 4-<br>section boom  | 601      | 253    | 708                | 321    | -106      | -48    | -2,280            | -1 035 | 2,882     | 1 307  |
| 16.0 x 24.0 tires  | -1,430   | -649   | -715               | -324   | -715      | -324   | -715              | -324   | -715      | -324   |
| Hookblock at bumper  | 350      | 176    | 577                | 261    | -227      | -103   | —                 | —      | —         | —      |
| Headache ball at bumper  | 325      | 147    | 506                | 230    | -81       | -82    | —                 | —      | —         | —      |
| Auxiliary lifting sheave   | 75       | 34     | 243                | 110    | -168      | -76    | -168              | -76    | 243       | 110    |
| 14' 6" (4.42 m) A-frame jib stowed   | 575      | 261    | 1,337              | 606    | -762      | -346   | -762              | -346   | 1,337     | 606    |
| 24' (7.32 m) lattice fly stowed  | 480      | 218    | 922                | 418    | -442      | -200   | -442              | -200   | 922       | 418    |
| 2-section boom and counterweight<br>reduction  | -3,956   | -1 794 | -3,632             | -1 647 | -324      | -47    | -324              | -147   | -3,632    | -1 647 |

① Adjust gross vehicle weight & axle loading according to component weight.

Note: All weights are ± 3%.

| Tire               | Max. Axle Load @ 20 mph (32.7 km/h) |
|--------------------|-------------------------------------|
| 16.00 x 24 (16-PR) | 26,200 lbs. (11 884 kg)             |
| 20.50 x 25 (20-PR) | 28,400 lbs. (12 882 kg)             |

● Link-Belt is a registered trademark.

We are constantly improving our products and therefore reserve the right to change designs and specifications.

**Link-Belt Construction Equipment Company** Lexington, Kentucky

A unit of Sumitomo Construction Machinery Co., Ltd.