

GENERAL INFORMATION ONLY

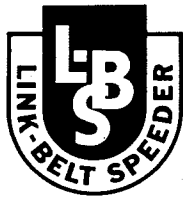

**FLYSHEET**  
**YC-18**  
**7½ TON**

**HYDRAULIC**  
**SELF-PROPELLED**  
**CRANE**

13'-21' TWO SECTION POWER BOOM

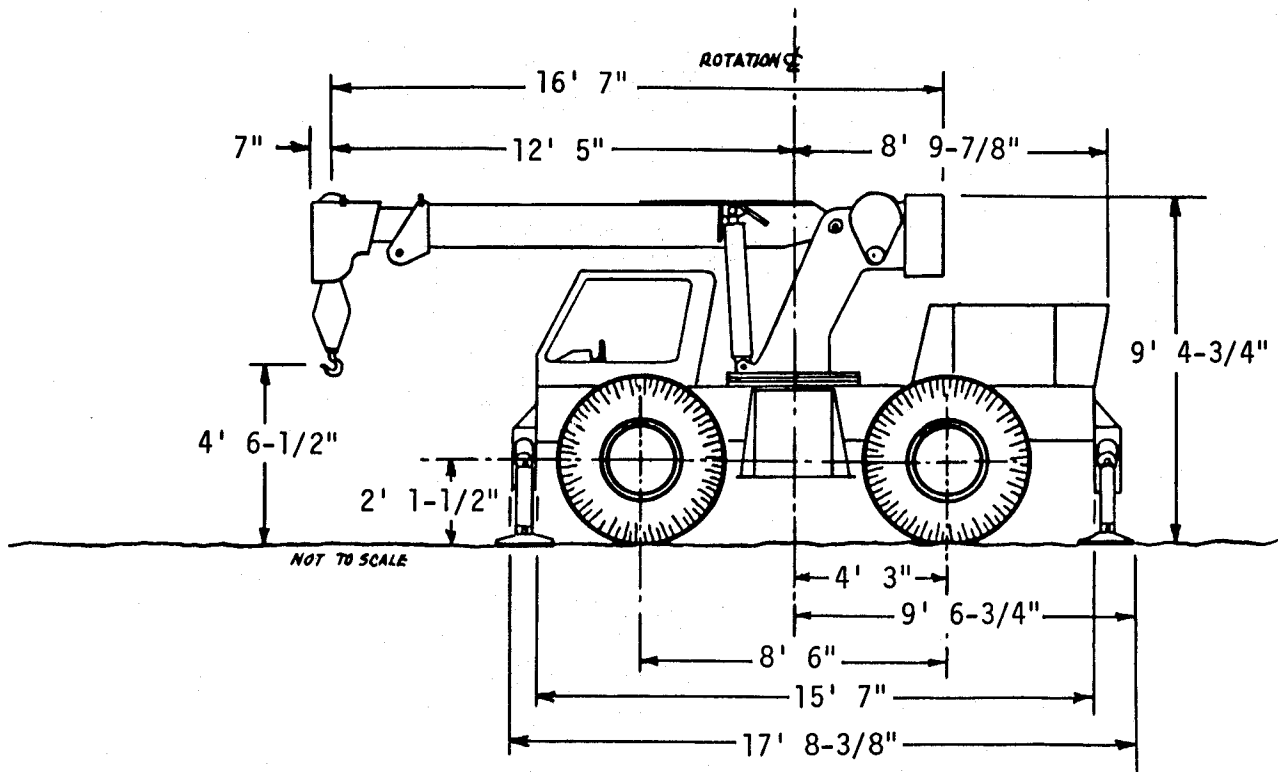

**DIMENSIONS AND WORKING RANGES**  
**CARRIER — 4 x 4, 8' 0" WIDE**

**BOOM HORIZONTAL OVER FRONT**

Overall length — standard boom retracted	21'-11½"
Overall length — standard boom extended	29'-11½"
Overall width — outriggers retracted (over tires)	8' 0"
Overall width — outriggers extended	12' 10"
Wheelbase	8' 6"
Tailswing of counterweight	4' 2"
Minimum ground clearance — rear axle	1' 3⅜"
Track — center to center front tires	6' 8⅜"
Travel Speed — with standard 14:00 x 24, 10-ply tires	25 m.p.h.*
Swing speed	4.0 r.p.m.
Approx. working weight	25,590#
Turning radius — over outrigger corners	16' 0"

\* 40 m.p.h. with optional 14:00 x 20, 18-ply Super Road Lug tires.

# GENERAL INFORMATION ONLY

## AXLE LOADINGS

STANDARD BASIC MACHINE	Gross Vehicle Weight	Boom Over Front		Boom Over Rear	
		Front	Rear	Front	Rear
Std. 13'-21' Power Boom	25,584#	10,745#	14,839#	11,658#	13,926#
	26,067#	14,501#	11,566#	15,415#	10,652#
Std. 13'-21' Power Boom with 8' opt. section	26,012#	11,314#	14,698#	11,516#	14,496#
	26,495#	15,071#	11,424#	15,273#	11,222#
Std. 13'-21' Power Boom with 15' opt. section	26,326#	12,223#	14,103#	10,922#	15,404#
	26,809#	15,979#	10,830#	14,679#	12,130#

Shaded weights apply to machine with optional Cat. D-3145 diesel engine.

## YC-18 CAPACITIES

PCSA Class 10-  
Refer to ALL notes at bottom of page.

Capacities are based on machine equipped with 13'-21' 2-section full power boom and 14:00 x 24, 10-ply rating tires.

13' - 21' STANDARD BOOM			
Radius	On Outriggers	On Tires	
	360°	Over Front	360°
10'	15,000*	14,720*	10,780
11'	14,000*	13,290*	9,150
12'	13,000*	12,060*	8,030
13'	11,850*	11,010*	7,080
14'	10,700*	9,970	6,310
16'	9,400*	8,060	5,110
18'	8,350*	6,720	4,260
20'	7,400*	5,720	3,610
13' - 21' BOOM PLUS 8' MANUAL SECTION			
22'	6,500	5,210	3,350
24'	5,800	4,570	2,920
26'	5,150	3,990	2,500
28'	4,550	3,620	2,280
13' - 21' BOOM PLUS 15' MANUAL SECTION			
30'	4,100	3,270	2,030
32'	3,770	2,950	1,810
32'	3,770	2,950	1,810
34'	3,450	2,680	1,620
36'	3,150	2,430	1,450

\*Maximum capacities based on factors other than machine's tipping condition.

## NOTES

- For lifting 15,000 pounds with 1/2" rope, 3 parts of 1/2" type "N" hoist rope required.
- Capacities shown are in pounds, and unless indicated by an asterisk (\*), are based on 85% of minimum tipping loads, with machine standing level on firm ground. The user is expected to make allowances for job conditions such as soft or uneven ground, sudden stopping of loads, or other unfavorable job conditions. The operator should be fully acquainted with the "Operator's

Manual" furnished by the manufacturer before operating this machine. Deduction must be made for weight of hook block, hook, sling, grapple, etc.

- "Over Front" lifting capacities for rated loads are limited to 20" each side from centerline of machine. (See Working Area Chart).
- When extending boom with load do not exceed the lifting capacity and radius indicated in above chart.
- The maximum load that can be telescoped in or out is not definable. It is permissible to try and telescope a load as long as it is not telescoped out past the radius for that load stated on the capacity chart for the machine operating condition.
- "On-Tires" Capacities — require mechanical axle lock-outs in "lock" position.

## WORKING AREAS

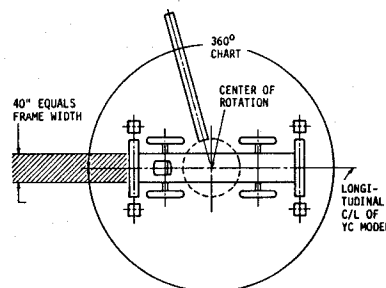

## BOOM RANGES

HORIZONTAL BOOM RANGE* Two Section Power Boom	BOOM LENGTHS		
	Std. 13' - 21' Power Boom	13' - 21' P. B. plus 8' Section	13' - 21' P. B. plus 15' Section
Minimum	12' - 4 1/16"	12' - 8 5/16"	20' - 8 5/16"
Maximum	20' - 4 1/16"	28' - 8 5/16"	35' - 8 5/16"

\*Measurement from centerline rotation to center of boompoint sheaves.

## YC-18 GENERAL SPECIFICATIONS

### CARRIER

**FRAME** — Box section, reinforced, with integral outrigger boxes.

**FRONT AXLE** — Clark planetary Model DS-12000, frame mounted, 80-13/16" track. No-spin differential — optional.

**REAR AXLE** — Clark planetary Model DS-12000, oscillating mount. No-spin differential — optional.

**AXLE DRIVE DISCONNECT** — For over-the-road operation — an operator controlled, pull-type T-handle disconnects rear axle drive.

**AXLE OSCILLATION LOCKOUTS** — For lifting loads "on tires," machine is equipped with mechanical hinge-type lockouts, controlled from ground.

**WHEELS AND RIMS** — Integral. 10" rims with std. tires, and 11 1/4" rims with optional 14:00 x 25, 20-ply rating, tube type Goodyear Road Lug tires.

**TIRES** — Single, front and rear.

**Standard** — 14:00 x 24, 10-ply rating, tubeless Goodyear Sure Grip Grader Lug.

**Optional** — 14:00 x 20, 18-ply rating, tube type Goodyear Super Road Lug.

14:00 x 20, 18-ply rating, tube type Goodyear All Service Non-directional Lug.

# GENERAL INFORMATION ONLY

16:00 x 24, 12-ply rating, tubeless Goodyear Sure Grip Grader Lug.

16:00 x 25, 20-ply rating, tube type Goodyear Road Lug.

**OUTRIGGERS** — Integrally welded to main frame; floats swivel mounted to arms; hydraulically power operated double acting cylinders with check valve maintains outrigger set. Control levers and valves conveniently located to right and left of operator.

## BRAKES —

**Service** — Four-wheel power hydraulic, internal expanding, foot pedal operated. Hydrovac booster.

### Size and Area —

**Front and Rear Wheels** — 16 $\frac{1}{4}$ " x 2 $\frac{1}{2}$ ", 314.6 sq. in. lining area.

**Parking** — Rockwell, 10" x 1 $\frac{1}{2}$ ", internal expanding on front axle drive tube, mechanically applied from operator's cab, locks the transmission drive shaft and the front axle for holding the machine.

**Emergency** — Four-wheel service brakes are applied with foot pedal and held with a dash mounted Mico brake lock.

**STEERING** — Power hydraulic. Front wheel steering controlled by steering wheel, rear wheels controlled by lever mounted on dash in front of operator. The two front and rear power steering cylinders are interchangeable.

**Turning Radius** — 16' 0" over corner of retracted outriggers.

**CAB** — Optional. One-man cab with tinted overhead glass. Cab doors also optional.

**ELECTRICAL SYSTEM** — 12-volt system.

**FUEL TANK** — Capacity 35 gals. Tank is a combination fuel tank and tool box with filler pipe inside the tool box. Tank cannot be tampered with when tool box lid is closed and locked.

**STANDARD EQUIPMENT** — Front and rear pintle hooks, rear steer lever, horn, and 5 lb. dry chemical fire extinguisher. Instrument panel and dash includes speedometer, ammeter, ignition switch, engine choke, diesel shut-down and gauges for fuel, engine temperature, oil pressure, and torque converter temperature.

**OPTIONAL EQUIPMENT** — Heater and fan-type defroster, headlights, tail lights, turn signals, electric windshield wiper, no-spin differential, and rear steer indicator.

## ENGINES — POWER TRAIN

**ENGINES** — Gasoline or diesel, 12-volt alternator, starter, pressure lubrication, radiator, air cleaner. Engine hood doors standard. Heat exchanger for power shift and torque converter oil.

	Chrysler LH-318 Gas	Cat. D-3145 Diesel	GM4-53N (5043) Diesel
Cylinders — Cycle	8 - 4	8 - 4	4 - 2
Bore — Stroke	3.91" - 3.31"	4.5" - 4.1"	4 $\frac{1}{2}$ " - 3 $\frac{7}{8}$ "
Displacement	318 cu. in.	522 cu. in.	212 cu. in.
Max. brake h.p. — full load speed	95 @ 2,200 r.p.m.	95 @ 2,200 r.p.m.	95 @ 2,200 r.p.m.
Peak torque	220 ft. lbs. @ 2,200 r.p.m.	217 ft. lbs. @ 1,820 r.p.m.	222 ft. lbs. @ 1,500 r.p.m.

**TORQUE CONVERTER** — Standard. Assures smooth transfer of engine power to the transmission and drive tubes in all shift ranges, forward and reverse. Converter cushions engine torque in drive components, virtually eliminates engine stall. Heat exchanger for torque converter and power shift oil provided in radiator lower tank.

**TRANSMISSION** — Power Shift. Hi-Low and Forward/Reverse. One operating lever power shifts transmission into high or low speed range while traveling — no need to stop machine.\* A separate lever shifts transmission into forward or reverse. Levers conveniently located at the side of the operator.

**TRANSMISSION** — Manual. One mechanically controlled lever easily pre-selects the high-low range. Then, with the foot pedal and shift lever, the operator smoothly shifts the synchro-mesh transmission gears into 1st or 2nd speed. The combination of high-low range and synchro-mesh 2-speed offers a total of four speeds. These four speeds, combined with the power shift transmission high-low range, provide a total of eight-speeds forward and reverse. Shift levers conveniently located at operator's side.

**UNIVERSALS** — Mechanics needle bearing.

## HYDRAULIC SYSTEM

**SUMP TANK** — All-welded unit, sand blasted and sealed; baffled for strength, maximum deaeration and heat rejection; mounted to left side of machine; pressurized up to 10 p.s.i.; capacity 45 gallons. Total system capacity 75 gallons.

**FILTERS** — 2 replaceable 10 micron filters; a 100-mesh suction line strainer, and 6 strategically located magnetic wands to assist in maintaining a clean hydraulic system.

**PUMP** — Tandem gear-type, driven by universal shaft from front of engine providing 75.6 g.p.m. total capacity at 2,200 r.p.m. full load speed. 58 g.p.m. section powers boomhoist, hoist, extend and retract of boom; 17.6 g.p.m. section powers hydraulic swing motor, outriggers and front and rear steering.

## CONTROL VALVES —

**Single Spool** — Actuated by hand control through mechanical linkage; directs oil flow to swing motor.

**Double Spool** — Hand lever control through mechanical linkage; directs oil flow to outrigger cylinders.

**Three Spool** — Hand lever control through mechanical linkage; directs oil flow to hoist, boom hoist, and boom extend-retract circuits.

## RELIEF VALVES —

**Main Hydraulic System** — Provided to maintain maximum system operating pressures. Boomhoist, wire rope hoist, extend-retract circuits set for 2,200 p.s.i.; swing, outrigger and power steering circuits set for 2,000 p.s.i.

## HOLDING VALVES —

**Wire Rope Hoist Mechanism** — Located between main control valve and motor. Provides control of overhauling loads.

**Boom Hoist** — Located between main control valve and boomhoist cylinders. Provides controlled lowering of boom.

## UPPER REVOLVING FRAME

**BOOM SUPPORT** — All-welded, stress relieved and jig line bored.

**TURNTABLE BEARING WITH INTEGRAL SWING GEAR** — Ball bearing type; outer race is bolted to boom support. Inner race with integral internal swing gear is bolted to carrier.

\*Down shifting (hi to lo) when engine is at, or near, governed engine speed is not recommended.

# GENERAL INFORMATION ONLY

**SWING SYSTEM** — 360° continuous rotation. Consists of a control valve, a cross-over relief valve, hydraulic motor, spring applied and hydraulically released brake, speed reducer, and swing pinion.

**Swing Pinion** — Heat treated, machine-cut teeth.

**Swing Motor** — Gear type, flange-mounted to speed reducer.

**Speed Reducer** — Link-Belt Speeder; three shaft, spur gear; anti-friction bearings throughout. Interchangeable with wire rope hoist system speed reducer.

**Swing Brake** — 2 shoe external contracting. Spring-applied, hydraulically released.

**Swing Speed** — 4.0 r.p.m.

**COUNTERWEIGHT** — 4,023 lbs., bolted to rear of boom support.

## **BOOM ATTACHMENT**

**BOOMHOIST** — Two double acting hydraulic cylinders with integral check valves. Self-aligning steel bushings in each cylinder end. Cylinder bore — 6½" dia.; rod diameter 3½", stroke 35". Boomhoist speed to 75° — 10.4 seconds.

**WIRE ROPE HOIST SYSTEM** — Consists of a control valve, manually operated through mechanical linkage; a hydraulic gear motor, spur gear reducer, spring applied and hydraulically released brake, wire rope drum with rope, and a holding valve for power controlled load lowering.

**Wire Rope Hoist Motor** — Gear type, flange mounted to speed reducer.

**Speed Reducer** — Link-Belt Speeder; three shaft, spur gear; anti-friction bearings throughout. Interchangeable with swing system speed reducer.

**Brake** — Two shoe external contracting, spring applied and hydraulically released.

**Brake Drum** — Mounted on speed reducer input shaft.

**Wire Rope Drum** — 11½" root dia. by 18" long; mounted on shaft which is mounted on anti-friction bearings. Capacity — 360' ½" diameter wire rope.

**Wire Rope** — Standard 3 part, ½" dia., Type "N."

**Single Line Pull and Speed** —

1st layer of rope — 7,180 lbs. pull maximum.

1st layer of rope — 212 f.p.m. maximum.

**WIRE ROPE** — Type "N" — 6 x 25 (6 x 19 class) filler wire, extra improved plow steel preformed, independent wire

rope center, right lay, regular lay.

**BOOM TELESCOPE SYSTEM** — Link-Belt Speeder exclusive design. Two section power hydraulic boom telescopes via a single double-acting cylinder mounted within the boom. The power boom sections are identified as follows — base section and #1, the tip power boom section. The cylinder rod end is pinned to the base section, and its cylinder is pinned to the lower end of the #1 section. The rod remains stationary, the cylinder extends and retracts the #1 section. A pilot operated check valve, located in the end of the cylinder oil circuit, prevents extension or retraction of the #1 section in the event of loss of hydraulic pressure.

**Interlock** — To extend boom, operator must simultaneously actuate the crane hoist mechanism thus releasing the hoist rope drum brake and paying out the hoist rope to avoid "two-blocking" while extending boom. Boom retract is independent of the interlock.

## **BOOM TELESCOPE SPEEDS —**

**Extend** — 88 f.p.m.

**Retract** — 202 f.p.m.

**TWO SECTION POWER BOOM** — Sections, standard and optional, are box type construction, high strength, low alloy steel. The #1 power boom section is supported by, and slides on, Teflon impregnated shoes. Base section attached to boom support with 3½" dia. heat treated steel pin. Boom consists of 3 basic parts — base section, #1 power boom section, and 1 double-acting (extend-retract) telescoping cylinder.

**Optional Boom Sections** — 8' long or 15' long are available. The optional manual boom sections pin to, and are powered by, the #1 power boom section. Only one manual section can be used at any one time.

**Boompoint Machinery** — Standard, 1 top idler and 2 lower hoist sheaves mounted on anti-friction bearings. Machinery is self-contained, and can be pinned to either the #1 power boom section or a manual boom tip section.

**Rope Guide Rollers** — 2 furnished, one at top end of boom base section, and one at top end of #1 power boom section.

**Hook Block** — Optional, 10-ton capacity.\*

**Weighted Ball with Swivel Hook** — Optional, 5-ton capacity.\*

\*Must not be loaded beyond machine's rated capacity.

We are constantly improving our products and therefore reserve the right to change designs and specifications. For certified dimensions, consult factory.



# Link-Belt Speeder

DIVISION OF FMC CORPORATION

Cedar Rapids, Iowa • Woodstock, Ontario, Canada • Queretaro, Mexico • Milan, Italy

