

STANDARD COMPONENTS INCLUDE:

Boom, boom rest, boom hoist cylinder, 2-speed winch, load line and 5 ton (4,5 mt) overhaul ball, turret with 8,300 lbs (3,765 kg) counterweight, ride-around operator control station with seat, wireless LMI & ATB protection systems, sub-frame with access ladders & integrated radio remote controlled outriggers, 3-section pump, hydraulic reservoir and oil cooler.

HYDRAULICS

- 8-Bolt direct mounted PTO with SAE C output (factory mounted units only)
- Three section vane pump, SAE C input

Pump Section	2000 RPM	2000 RPM
Shaft End Pump:	41.67 GPM @ 100 PSI	158 LPM @ 100 PSI
Center Pump:	28.33 GPM @ 100 PSI	107 LPM @ 100 PSI
Cover End Pump:	11.67 GPM @ 100 PSI	44 LPM @ 100 PSI

- Hydraulic reservoir - 115 gallon (435 liter) capacity

WARNING SYSTEMS

- Wireless LMI with display and crane function shut-offs for overload protection
- Wireless anti-two block system

OPTIONS

- Single front stabilizer (front stabilizer required on all SHL)
- 8' (2,4 m) Flatbed - wood or steel
- 24" (610 mm) Bulkhead
- 5/8" (15,9 mm) Diameter 6 x 25 EIPS IWRC wire rope
- Auxiliary winch same as main, includes rooster sheave
- Auxiliary lower sheave block for 7 to 8 part line
- Load block - 1, 3 & 5 sheave options
- Operator cab with diesel heater, air conditioner (hydraulic) upgrade option
- Three-section gear pump, SAE C input

BOOM

- 40 Ton (36,3 mt) capacity @ 5' (1,5 m) radius
- 3-Section 77' (23,4 m) proportional boom
- 5-Sheave quick reeve boom point

HOIST

- Maximum theoretical line speed 453 fpm (138 mpm)
- Maximum theoretical bottom-layer line pull 13,050 lb (5,919 kg)
- Wire Rope – 380' (115,8 m) 5/8" (15,9 mm) diameter rotation resistant

In order to ensure continuous improvement, Manitex reserves the right to change design and specifications without notice.

- Hose reel - boom mounted
- Toolboxes
 - 24" L x 20" W x 18" H (610 mm x 508 mm x 457 mm)
 - 48" L x 18" W x 18" H (1220 mm x 457 mm x 457 mm)
- 2-Person gravity leveled non-rotating basket - 600 lb (272 kg) capacity
- 2-Person gravity leveled rotating (manual) basket - 1,200 lb (544 kg) capacity
- 4-Function radio remote crane control system 900 MHz
- 4-Function radio remote crane control system 433 MHz

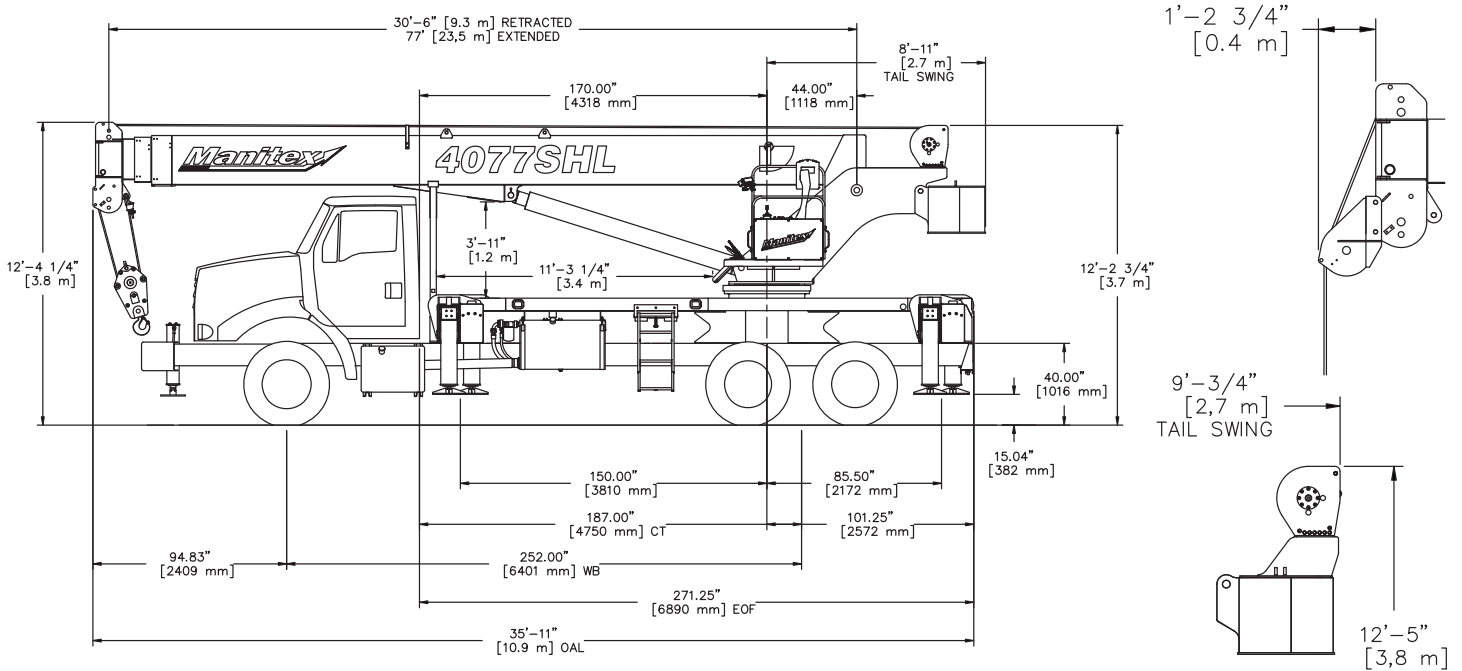

CHASSIS DATA	4077SHL
Wheelbase (WB)	252" 6 401 mm
Cab to Tandem (CT)	187" 4 750 mm
Cab to End of Frame (EOF)	271" 6 883 mm
Frame Section Modulus at 180°/360° Area of Operation	25.0 in ³ 110,000 psi 758 422 kPa
Front Axle Gross Weight Rating	20,000 lb 9 072 kg
Rear Axle Gross Weight Rating	44,000 lb 19 958 kg
Minimum Truck Axle Weight - Front**	9,800 lb 4 445 kg
Minimum Truck Axle Weight - Back**	8,000 lb 3 629 kg
Nominal Frame Width	34" 864 mm

*Frame section modulus at 360° area of operation requires front bumper stabilizer. **Minimum chassis weight is required to meet 85% stability requirements. Chassis data is general - not for engineering. Some dimensions depend on truck selection.

WEIGHTS	4077SHL
Crane Without Cab	34,535 lb 15 664 kg
Cab Alone	575 lb 261 kg
Flat Bed 8' (2,40 m)	750 lb 340 kg

MAXIMUM TIP HEIGHT (A)	4077SHL
Configuration	Boom 77' 23,5 m
Extended Boom	86' 5" 26,3 m

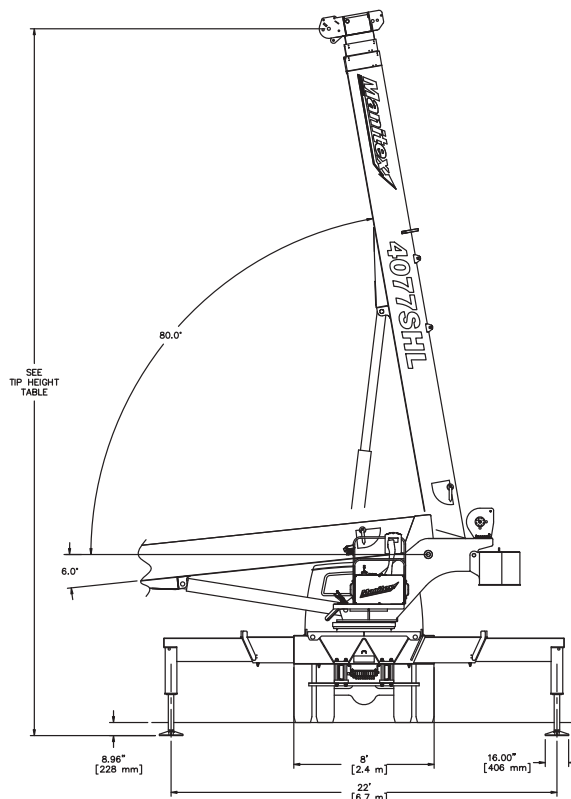

FULL SPREAD

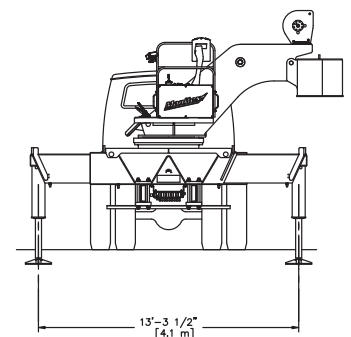

INTERMEDIATE SPREAD

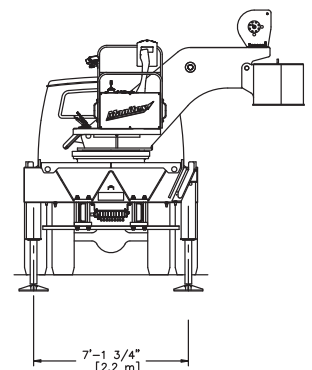

RETRACTED SPREAD