

STANDARD COMPONENTS INCLUDE:

Boom, boom rest, boom hoist cylinder, 2-speed winch, load line & 5 ton (4,5 mt) overhaul ball, turret with 6,400 lb (2,903 kg) counterweight, ride-around operator control station with enclosed cab, cab heater, wired LMI & ATB protection systems, sub-frame with integrated radio remote controlled outriggers, single front stabilizer, aluminum deck with fixed access ladders, removable aluminum ladder, 3-section pump, hydraulic reservoir and oil cooler.

HYDRAULICS

- 8-Bolt direct mounted PTO with SAE C output (factory mounted units only)
- Three section vane pump, SAE C input

Pump Section	2000 RPM	2000 RPM
Shaft End Pump:	41.67 GPM @ 100 PSI	158 LPM @ 100 PSI
Center Pump:	35 GPM @ 100 PSI	133 LPM @ 100 PSI
Cover End Pump:	11.67 GPM @ 100 PSI	44 LPM @ 100 PSI

- Hydraulic reservoir - 115 gallon (435 liter) capacity

OPTIONS

- Bridge legal options available - consult Manitex
- Intermediate & long subframe options for NO front stabilizer configuration - consult Manitex
- Three-section gear pump, SAE C input
- 32' [9,8 m] - 49' [14,9 m] 2 - Section telescopic jib; 0°, 15°, 30° offset positions
- Auxiliary winch same as main, includes rooster sheave
- Auxiliary lower sheave block for 9 to 10 part line
- 3rd Wrap limiter, main and auxiliary winch
- Loadblock - 1, 3, 4 & 5 sheave options
- Cab air conditioner (hydraulic)

BOOM

- 50 Ton (45,4 mt) capacity @ 6' (1,8 m) radius
- 4-Section 110' (33,5 m) proportional boom
- 6-Sheave quick reeve boom point

HOIST

- Maximum theoretical line speed 453 fpm (138 mpm)
- Maximum theoretical bottom-layer line pull 13,396 lb (6,076 kg)
- Wire Rope – 400' (122 m), 5/8" (15,9 mm) diameter rotation resistant, Flex X-35

WARNING SYSTEMS

- Wired LMI with crane function shut-offs for overload protection
- Graphical display
- Event recorder
- WADS - Work Area Definition System
- Wired anti-two block system

In order to ensure continuous improvement, Manitex reserves the right to change design and specifications without notice.

- Toolboxes
 - 24" L x 20" W x 18" H (610 mm x 508 mm x 457 mm)
 - 48" L x 18" W x 18" H (1220 mm x 457 mm x 457 mm)
- 2-Person gravity leveled non-rotating basket - 600 lb (272 kg) capacity
- 2-Person gravity leveled rotating (manual) basket – 1,200 lb (544 kg) capacity
- 2-Person gravity leveled rotating (manual) quick attach basket – 1,200 lb (544 kg) capacity
- 4-Function radio remote Crane control system 900 MHz
- 4-Function radio remote Crane control system 433 MHz

Notes:

Additional axles required for Federal Bridge legal configuration - Consult Manitex

Manitex highly recommends addition of a Front Stabilizer and may be required on some installations - Consult Manitex

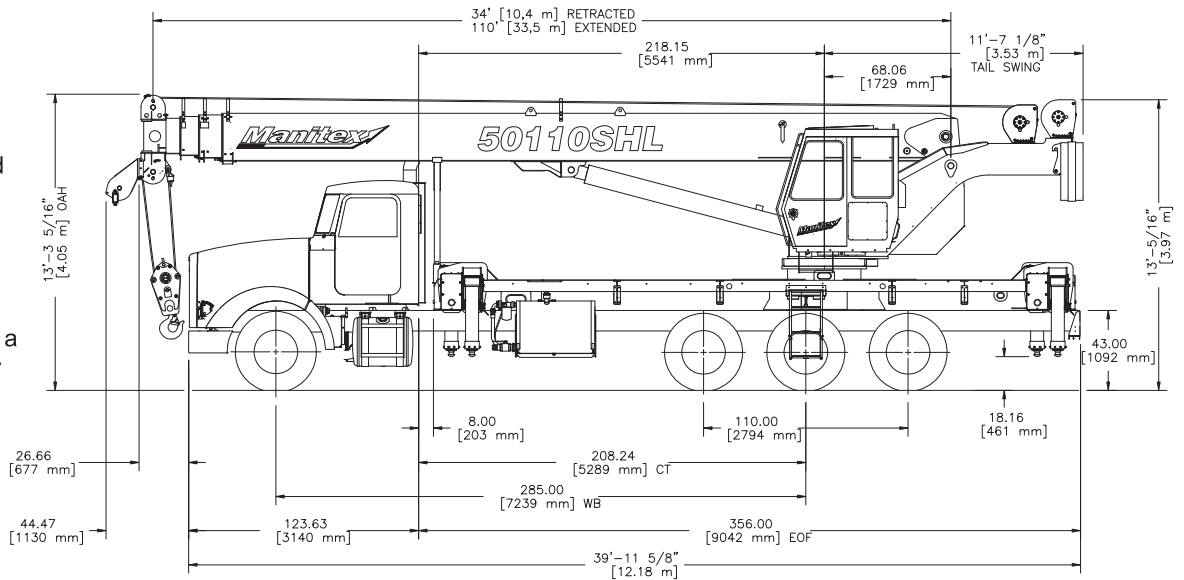

CHASSIS DATA	50110SHL
--------------	----------

Wheelbase (WB)	285" 7 239 mm
Cab to Tandem (CT)	208" 5 283 mm
Cab to End of Frame (EOF)	370" 9 398 mm
Frame Section Modulus	27.0 in ³ 120,000 psi 827 371 kPa
Front Axle Gross Weight Rating	20,000 lb 9 071 kg
Rear Axle Gross Weight Rating	58,000 lb 26 308 kg
Minimum Truck Axle Weight - Front*	10,700 lb 4 853 kg
Minimum Truck Axle Weight - Back* Excludes weight of 13.2k lift axle	15,200 lb 6 894 kg
Nominal Frame Width	34" 864 mm
<small>Chassis data is minimum general requirements-not for engineering. Actual dimensions and truck data will depend on truck selection and axle configuration. *Minimum chassis weight is required to meet 85% stability requirements.</small>	

WEIGHTS	50110SHL
---------	----------

Crane (Includes Cab and Platforms)	43,300 lb 19 640 kg
Cab	575 lb 261 kg
Aluminum Platforms	542 lb 246 kg
32' (9,72 m) to 49' (14,94 m) Telescopic Jib	1,870 lb 848 kg

MAXIMUM TIP HEIGHT (A)	50110SHL
------------------------	----------

Configuration	Boom 110' 33,5 m
Extended Boom	117' 35,6 m
Fixed or Retracted Jib	148' 45,0 m
Extended Jib	164' 50,1 m

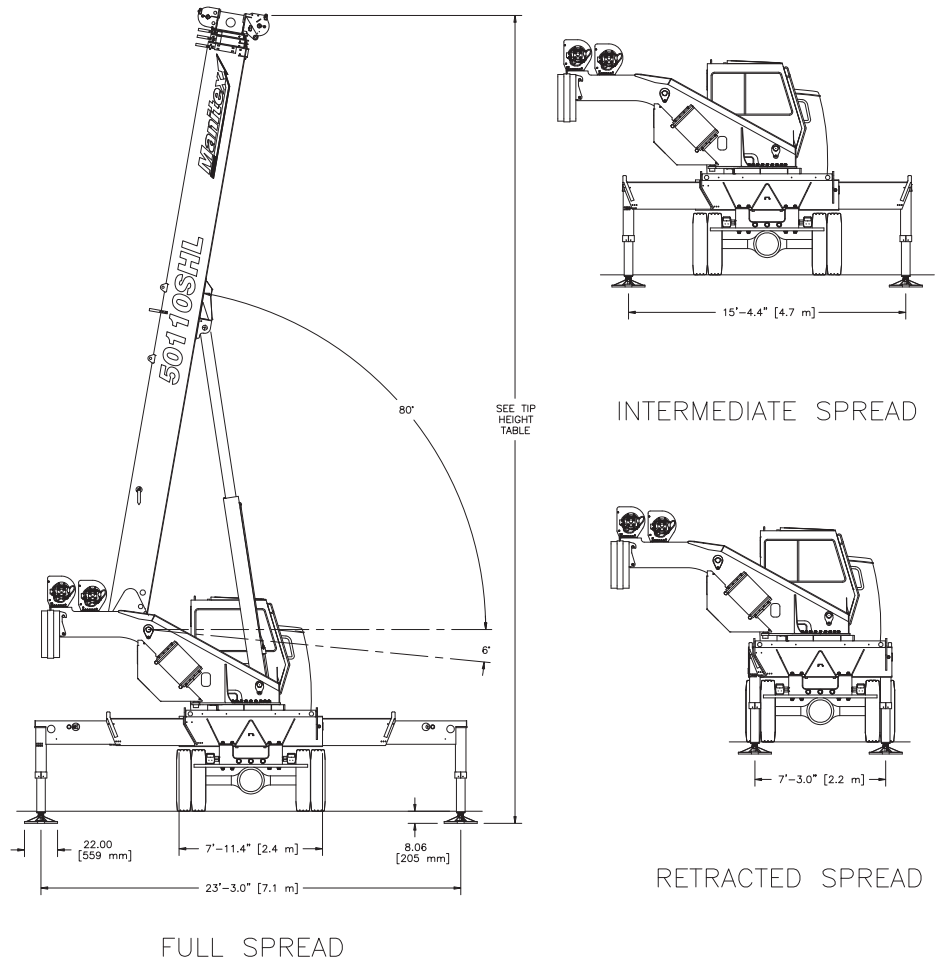

FULL SPREAD

INTERMEDIATE SPREAD

RETRACTED SPREAD